



Branded Programs

# Cruisin' Fried Chicken



## Cruisin' Fried Chicken

Cruisin' Fried Chicken is committed to:

- Profitable retailing locations
- Continued product development, research and marketing
- Innovative cooking systems
- Quality customer training and support

# Cruisin' Fried Chicken



## CRUISIN' UNIFORMS



The Cruisin' "Program" may consist of the following:

- Equipment Package
- Signage
- Graphics Package
- Packaging
- Product

# Cruisin' Fried Chicken

Benefits of signing an agreement include:

- Use of Cruisin' Fried Chicken Name and Logo
- Consistent quality products and service
- Cruisin' Fried Chicken POP material
- Grand opening kit
- Operations Manuals
- Continued program support through ACE visits
- Nationally recognized brand

The Most Amazing part of the program is what we've left out!

- No Royalty Fees
- No Franchise Fees

# Time and Labor Saving Equipment



Indoor and Outdoor  
Signage identifies  
the location to make  
the Cruisin' QSR a  
destination



# Cruisin' Fried Chicken Products

- Marinade 1/25lb 623264
- Batter Dip 1/25lb 623272
- Breading 1/40lb WC623298 CAJ623280
- Shortening 1/35lb 800433
- Packaging next page
- Filter Powder 60ct. 642512



# The Cruisin' Graphics Package provides immediate brand recognition

Dinner Box Large	400/ct	623082
Picnic Box	125/ct	623090
Wax Bag	1000/ct	623215
Snack Box	500/ct	623249
Small Dinner Box	400/ct	623256

High quality,  
easily identifiable  
packaging that  
enhances brand  
recognition



# Counter Café

BY PICCADILLY CIRCUS PIZZA



OVER 20 YEARS IN THE C-STORE INDUSTRY!

DELICIOUS FOOD THAT IS EASY TO BAKE & EASY TO SELL!

FOOD FOR  
ALL DAYPARTS

## GET STARTED TODAY!

FREE market analysis

No franchise fees or  
on going royalties

We provide the initial training and  
on going support at no additional cost

Use existing equipment if possible

8 food category offerings

Breakfast - Lunch - Dinner

PIZZA



BREAKFAST



SANDWICHES



SNACKS



FOR MORE INFORMATION  
CONTACT:

LAND MARK PRODUCTS, INC.  
1007 OKOBOJI AVE • PO BOX 188 • MILFORD, IA 51351  
PCPIZZA.COM

800.338.4340

WE MAKE IT. SIMPLE.



# Counter Café

BY PICCADILLY CIRCUS PIZZA

## MENU OFFERINGS & SRP 2.22.07



COMPONENT PIZZA	PERSONALS	SMALL	MEDIUM	LARGE
CHEESE	\$3.49	\$8.99	\$10.99	\$13.99
1-TOPPING	\$3.49	\$8.99	\$10.99	\$13.99
SPECIALTY PIZZAS	\$3.89	\$11.99	\$13.99	\$16.99
BREAKFAST PIZZA	\$3.89	N/A	N/A	N/A
ADDITIONAL TOPPINGS	39¢	79¢	99¢	\$1.29

FREEZER TO OVEN PIZZA	PERSONALS	12" FAMILY SIZE	MEGA SLICE
CHEESE	\$3.49	\$8.99	\$2.39
1-TOPPING	\$3.49	\$8.99	\$2.39
SPECIALTY PIZZAS	\$3.89	\$8.99	\$2.39
BREAKFAST PIZZA	\$3.89	N/A	N/A
ADDITIONAL TOPPINGS	39¢	79¢	N/A

MADE TO ORDER SUBS	4"	12"	GRAB-N-GO SUBS	4"
CLUB COMBO	\$3.99	\$5.99	CLUB COMBO	\$3.99
HAM	\$3.79	\$5.89	HAM	\$3.79
TURKEY	\$3.79	\$5.89	TURKEY	\$3.79
ROAST BEEF	\$3.99	\$5.99	ROAST BEEF	\$3.99
VEGETARIAN	\$2.29	\$4.29	ITALIAN	\$3.49
ITALIAN	\$3.49	\$5.79	COLD CUT COMBO	\$3.49
COLD CUT COMBO	\$3.49	\$5.79		
BBQ	\$3.79	\$5.99		
MEATBALL	\$3.79	\$5.99		
TACO	\$3.79	\$5.99		
EXTRA CHEESE	\$0.50	\$1.00		
ADD BACON	\$0.50	\$1.00		
DOUBLE MEAT	\$1.00	\$2.00		

CHICKEN	6/PK	12/PK
CLASSIC HOT WINGS	\$2.99	\$5.99
BONELESS BUFFALO WINGS	\$2.79	\$5.99
GOURMET CHICKEN TENDERS	3/PK	\$2.79

SANDWICH SENSATIONS (PRE-MADE)		BREADSTICKS	2/PK	6/PK
PEPPERED TURKEY & SWISS	\$3.29	GARLIC STICKS	\$1.19	\$2.79
ON HONEY WHEAT ROLL		CHEESE STICKS	\$1.59	\$3.89
SMOKED HAM & CHEDDAR	\$3.29	CINNAMON STICKS	\$1.59	\$3.89
ON PEPPERCORN RANCH ROLL				
SPICY ITALIAN ON ASIAGO ROLL	\$3.29			
CLUB COMBO ON ASIAGO ROLL	\$3.29			
CLASSIC CHEESEBURGER	\$3.59			

BREAKFAST	
SAUSAGE, EGG & CHEESE BISCUIT	\$2.39
HAM, EGG, & CHEESE CROISSANT	\$2.39
SAUSAGE, EGG, & CHEESE CROISSANT	\$2.39
SAUSAGE & EGG PANCAKE	\$2.39
SAUSAGE, EGG, CHEESE, POTATO AND SALSA BURRITO	\$1.99
CINNA-BLASTS MINI CINNAMON ROLLS	\$0.99



WE MAKE IT. SIMPLE.



# Counter Cafe

## KIOSK SPECIFICATIONS

LAND MARK PRODUCTS, INC. • 1007 OKOROJI AVE • PO BOX 188 • MILFORD, IA • 800-338-4340

### EQUIPMENT



#### HATCO GRSDS 24D - SLANT MODEL - DUAL SHELF WARMER



- 24" WIDE X 29 3/8" HIGH X 24" DEEP
- 1355 WATTS
- 120 VOLTS
- 11.3 AMPS
- SINGLE PHASE
- SHIPPING WEIGHT 128LBS



NEMA 5-15P

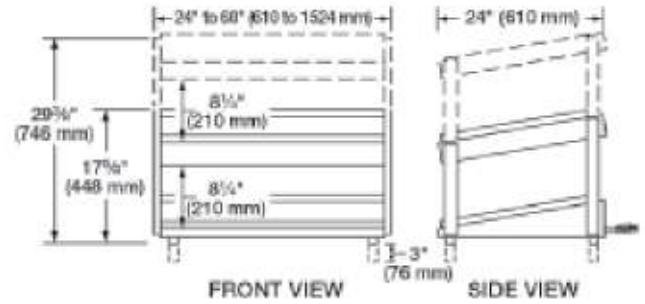

#### QBD MINI-ME REFRIGERATED DISPLAY CASE - DUAL SHELF COOLER



- 24" WIDE X 35.13" HIGH X 22.63" DEEP
- 120 VOLTS
- 6.8 AMPS
- 8 FT POWER CORD

DESIGNED TO OPERATE UNDER NORMAL STORE CONDITIONS OF 75° F WITH 50% RELATIVE HUMIDITY. CONDENSATION ON GLASS MAY OCCUR IN HOT/HUMID CONDITIONS.

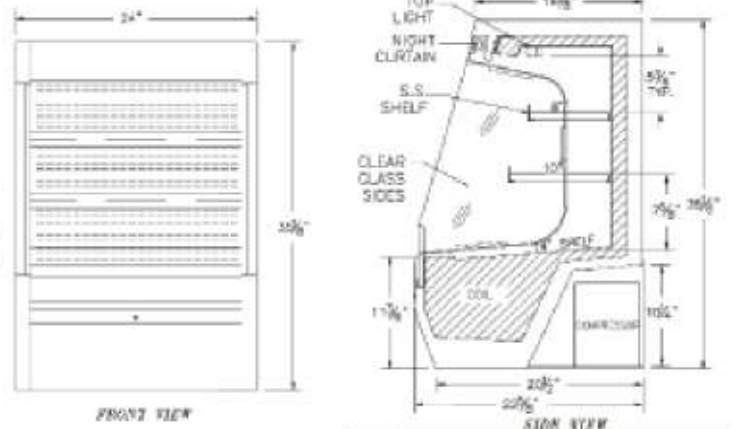

### KIOSK MEASUREMENTS



#### EQMERC500 - PICCADILLY CIRCUS PIZZA COUNTER CAFE KIOSK

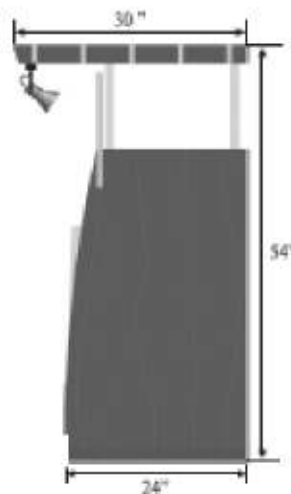
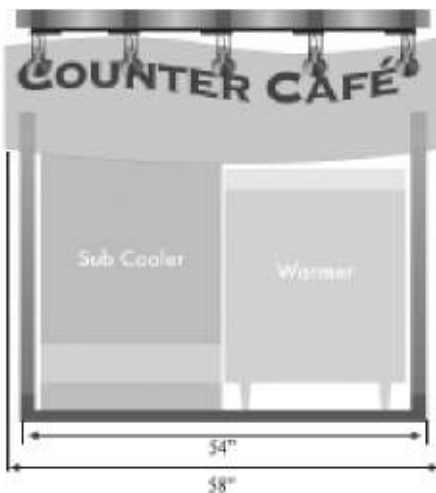

3D VIEW



**COMING SOON!**



**PICCADILLY CIRCUS PIZZA**

Located:



**PICCADILLY CIRCUS PIZZA**

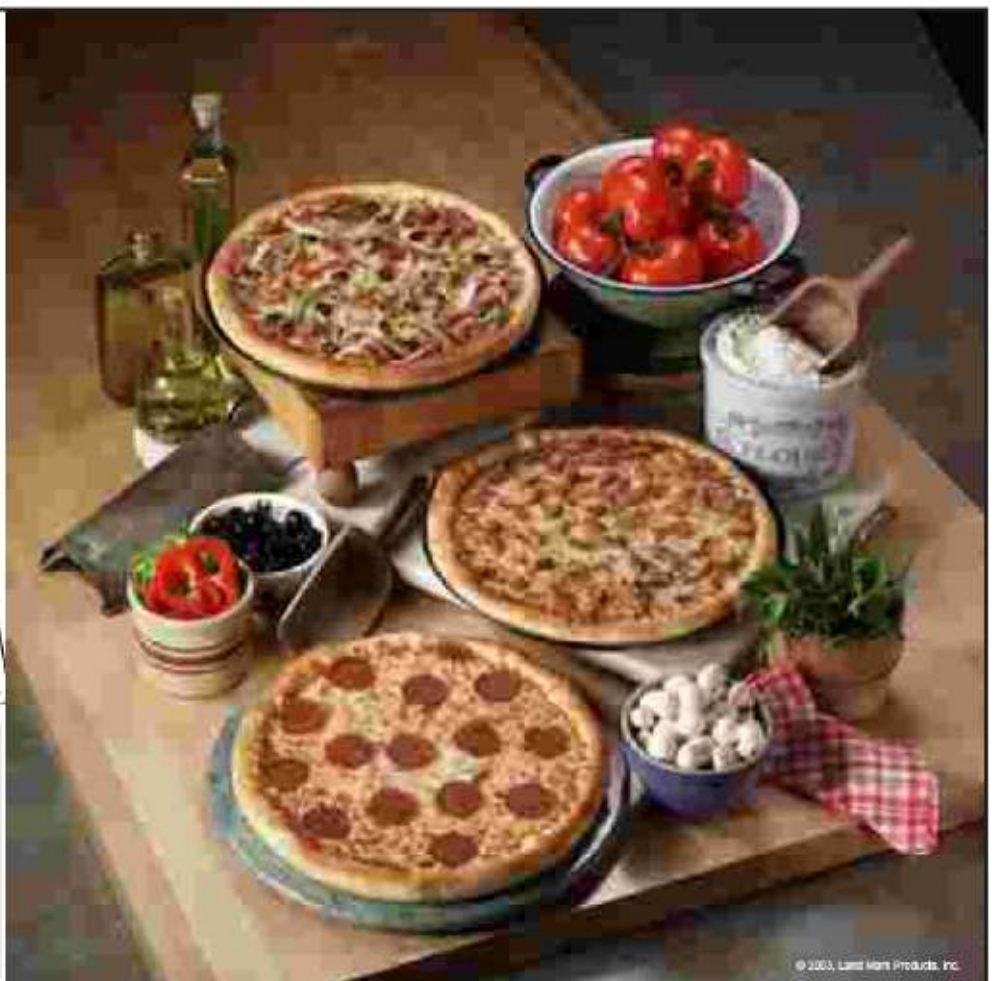

# EQUIPMENT





# BRAND POWER



## Brand Image

At Piccadilly Circus Pizza we believe it is vital not only to serve a quality product, but also to look professional while doing so. We strongly suggest that each deli employee be in uniform. This will build brand identity to your location and will let your customer know you're committed to the food service industry. Depending on the specific package that was selected, you will be receiving a variety of aprons, hats, and shirts.

For more information regarding uniform items, contact your territory manager. You may also call the corporate office, Land Mark Products, at 1-800-338-4340

## Brand Support

One of the advantages of partnering with the Piccadilly Circus Pizza Brand is Service! You will have a dedicated Piccadilly Circus Pizza representative helping your foodservice operation stay on the path to success. A local Territory Manager (TM) will be assisting in the opening of your location focused on cooking procedures, profitability, waste control & marketing. Your TM will be stopping at your location periodically throughout the year to help you along the way.

# BREAKFAST



# FRESH PIZZA



# FTO PIZZA



Made To Order Made To Order

# MTO SUBS

de To Order Made To Order



# APPETIZERS



# GRAB-N-GO SUBS





[our menu](#) | [nutritional info](#) | [isavor coupons](#) | [corporate](#) | [contact](#) | [resource center](#)



Welcome to the Piccadilly Circus Pizza Resource Center. The Resource Center gives Piccadilly Circus Pizza owners access to a host of useful resources for managing your stores 24/7. Just type in your name below to get started.

Operational Support

Marketing Support

Resource Network

Logos  
Graphics Library  
Product Images  
Ad Slicks  
Newspaper Ads  
Miscellaneous  
Marketing Management Forms

## Product Images

### Pizza



Pepperoni Mini



Combo Deluxe Mini



2 Minis



HELLO Carol, YOU ARE LOGGED IN!

LOGOUT